

# Digital Amperemeter A 9648

Measuring - and indicating range separate programmable

## Features

- LED-Display 14.2 mm red
- Display range  $\pm 9999(0)$  Digit
- Indicating range and decimal point programmable
- Measuring range programmable
- True RMS measurement (AC)
- Frequency range AC 15 ... 400 Hz
- Max. 4 outputs SPDT relay or transistor
- Isolated analog output  
0/4 ... 20 mA and 0/2 ... 10 V DC
- Front protection IP65



## General information

The Digital Amperemeter A9648 has been designed to measure DC and AC current signals. Five basis models are selectable and makes it possible to measure currents from 0... 0.900 mA to 0... 60.0 A. Within a model the measurement range is free programmable. Measuring bipolar currents is possible for example -20 ... +20 mA.

Additional free programmable display range within  $\pm 9999(0)$  digit can be assigned to a programmed current measurement range. This can be important, if the measured current is a degree for another physical dimension.

## Short information

Programming	Parameters are programmed via front-side membrane keypad.
Measuring input	With basic models 1-4 alternatively measurement of DC, $\pm$ DC (range always from negative to positive value) and AC (TRMS) current is possible. With basic model 5, only AC (TRMS) current measurement is possible
Alarm outputs	Switching performance min. or max., hysteresis, on-delay time and off-delay time are programmable in range from 1 s up to 9 h.
Digital filter	With activated digital filter last 16 measured values will be averaged continuously and the result shown in the display.
Analog output	Proportional to the input signal an isolated analog output signal 0 ... 20 mA/ 0 ... 10 V DC or 4 ... 20 mA/2 ... 10 V DC can be generated. Output changes automatically from current signal to voltage signal depending on burden.

## Technical data

### Power supply

Supply voltage	: 230 V AC $\pm 10\%$ ; 115 V AC $\pm 10\%$ , 24 V AC $\pm 10\%$ or 24 V DC $\pm 15\%$
Power consumption	: max. 3.5 VA, with analog output 5 VA
Operating temperature	: -10 ... +55 °C (14 ... 131 °F)
Rated voltage	: 250 V AC acc. VDE 0110 between input / output / supply voltage Degree of pollution 2, over-voltage category III
Test voltage	: 4 kV DC, between input / output / supply voltage
CE - conformity	: EN55022, EN60555, IEC61000-4-3/4/5/11/13

### Input

Measuring range	: Model 1-4 0 ... 0.9 mA to 6 A DC/AC <sub>TRMS</sub> Model 5 0 ... 4.5 bis 60 A AC <sub>TRMS</sub>
Input resistance	: Model 1 = 20 $\Omega$ , Model 2 = 2 $\Omega$ , Model 3 = 0.2 $\Omega$ , Model 4 = 0.02 $\Omega$ , Model 5 = integrated current transformer
Over load	: 2-times; 4-times max. 5s
Accuracy	: < 0.1 % $\pm 2$ Digit (DC); 0.5 % $\pm 2$ Digit (AC) Crest-factor<3 $\Rightarrow$ max. 2 % error, Crest-factor<5 $\Rightarrow$ max. 5 % error
Temperature coefficient	: 0.05 % / K

Display	: LED red, 14.2 mm
Display range	: $\pm 9999(0)$ digit, with leading zero suppression
Parameter display	: LED 2-digit red, 7 mm (Parameter - and output indicator)

### Output

Relay	: SPDT < 250 V AC < 250 VA < 2 A, < 300 V DC < 50 W < 2 A
Transistor	: max. 35 V AC/DC / 100 mA, short circuit protected
Analog output	: 0/4 ... 20 mA burden $\leq 500 \Omega$ ; 0/2 ... 10 V burden $> 500 \Omega$ , isolated Automatic output changing (burden dependent)
- Accuracy	: 0.1 %; TK 0.01 % / K

Panel case	: DIN 96x48 mm, material PA6-GF; UL94V-0
Dimensions	: Front 96x48 mm, mounting depth 100 mm,
Weight	: max. 390 g
Electrical connection	: Clamp terminals, 2 mm <sup>2</sup> single wire, 1 mm <sup>2</sup> flexible wire, AWG14
Protection	: Front IP65, terminals IP20, fingersafe acc. German BGV A3

## Dimension

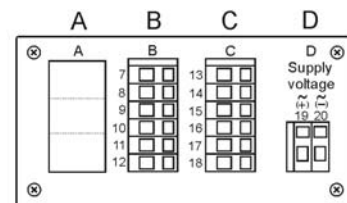
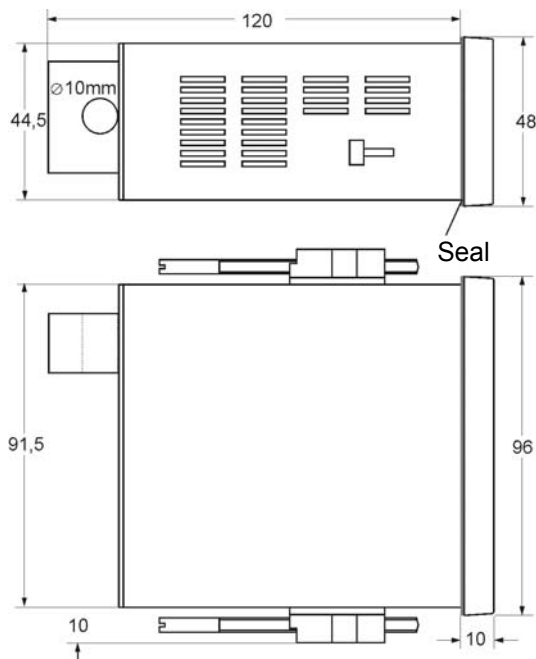

Position terminal strips

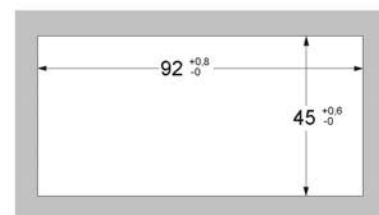

Panel cut-out  
acc. to DIN 43700-96x48

## Connection diagrams

### Terminal strip A

Model 1-4  
0 ... 0.9/6 A AC/DC

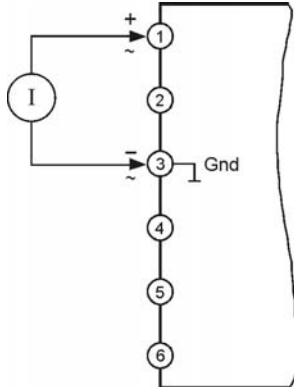

Model 5  
0 ... 4.5/60 A AC with installed current transmitter

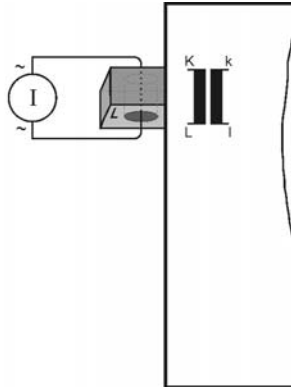

### Terminal strip B (varies with version)

2 alarm outputs

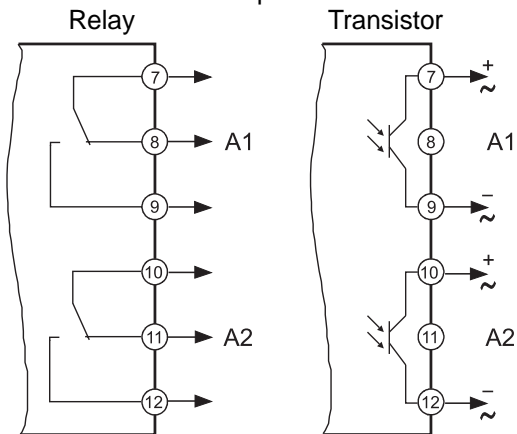

### Terminal strip C (varies with version)

2 alarm outputs

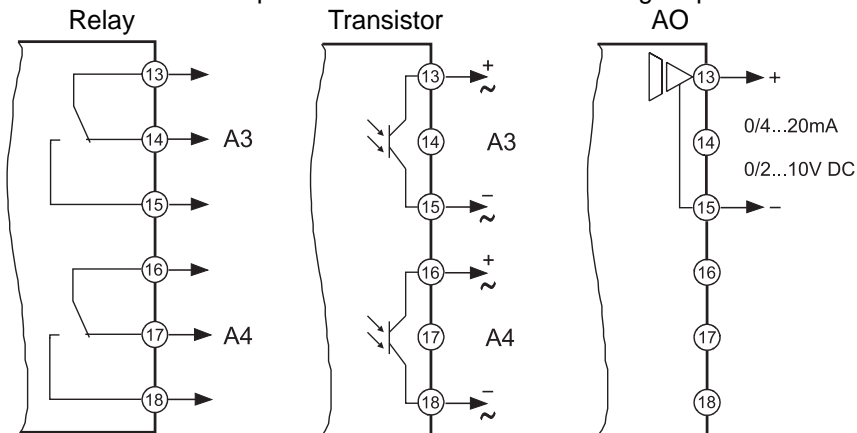

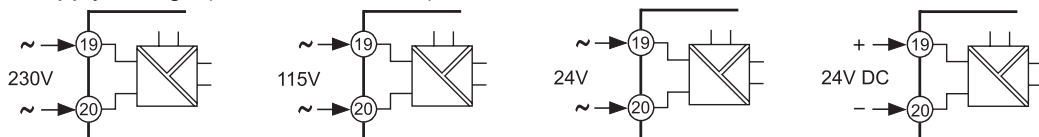

### Terminal strip D supply voltage (varies with version)

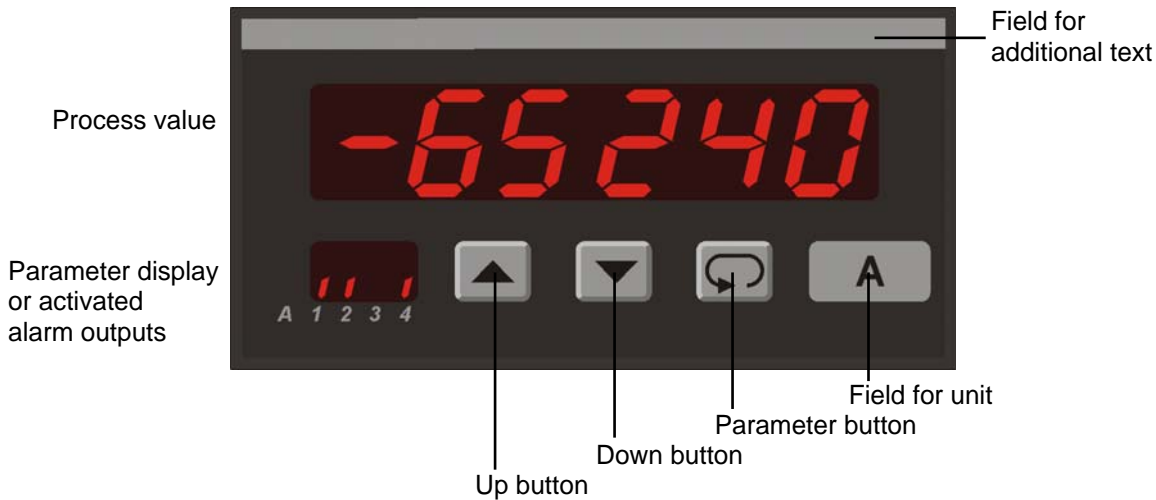

## Controls and indicators



### Description

Operation of the device is arranged in 2 levels. The requested parameter can be called by button . For selection within a parameter or for entering data, use buttons  and .

After powering up, the device is located in the **Working level**. Set points of the alarm outputs can be preselected if they are available.

Pressing the button  for more than 2 seconds, activates the **Configuration level**. Now all the parameters which defines the function of the panelmeter can be programmed. These are the measuring input, switching performance of the alarm outputs and the analog output signal.

After finishing the configuration or when no button was pushed for more than 2 minutes, the program returns to the working level. Leaving the configuration level is possible at any time by pressing the button  for more than 2 seconds.

Parameter display as status indicator for the alarm outputs A1-A4.

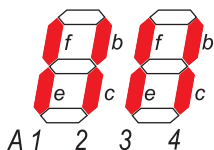

Segments f (A1 / A3) and/or b (A2 / A4) are flashing with 2 Hz, when delay time is active.

Segments e (A1 / A3) or c (A2 / A4) are output indicators.

### Error messages:

Display flashes      Overflow of the display range

*PE*      When reading this message in the parameter display, a parameter failure has been occurred. The display flashes. When pushing the button , the error code will be deleted and the device is running with factory settings. Configuration and function of the device must be checked. If the error occurs again, please ship the device to factory for repair service.

*Loc*      Programming lock active ⇒ see configuration page 7

### Start-up note:

Before setting into operation, the device must be configured for the intended use.

⇒ see page 6

## Notes to representation



Parameter is only displayed when configured



Parameter is only displayed when feature is included (see order code)

































**Please note:** All parameters can be called if they are not blocked by other programmed parameters and if they are available. **Factory settings** are shown in the display.

## Working level

Button	Display	Description
		Actual value. Alarm output indication (only if installed and activated).
		Display brightness (permanent changing possible ) Setting possible in 9 steps with buttons ▲ and ▼.
		Display maximum reading. Reset with buttons ▲ or ▼, or at every power off.
		Display minimum reading. Reset with buttons ▲ or ▼, or at every power off.
		Setpoint output A1. Setting possible from 5 t ... E n with buttons ▲ and ▼. 5 t (start value) ... E n (end value)

Note: The parameter settings for A1 ... A4 have to be configured the same way

## Configuration

Button	Display	Description (Display graphic shows factory settings)
 press 2 s	<div style="border: 1px solid black; padding: 5px; text-align: center;"> <math>1</math>  <b>OFF</b>  <hr/> <i>F<sub>d</sub></i> </div>	Digitalfilter <i>OFF</i> , <i>ON</i> Averaging of the last 16 measured values continuously. Selection with buttons  and  .
 	<div style="border: 1px solid black; padding: 5px; text-align: center;"> <math>2</math>  <b>0</b>  <hr/> <i>S<sub>c</sub></i> </div>	Indicating correction. Setting possible from -99(0) ... 99(0) digit with buttons  and  .
 	<div style="border: 1px solid black; padding: 5px; text-align: center;"> <math>3</math>  <b>0 ... 1</b>  <hr/> <i>I<sub>n</sub></i> </div>	Input signal <i>0 ... 1</i> DC current unipolar (range from 0 ... end value; see parameter 4) <i>-1 ... 1</i> DC current bipolar (range from e.g. -9 ... +9 mA) <i>IRMS</i> AC current TRMS Selection with buttons  and  .
 	<div style="border: 1px solid black; padding: 5px; text-align: center;"> <math>4</math>  <b>9.999</b>  <hr/> <i>II</i> </div>	Measuring range (end value) Model 1 0.900 ... 9.999 mA Model 2 9.00 ... 99.99 mA Model 3 90.0 ... 999.9 mA Model 4 0.900 ... 6.000A Model 5 4.50 ... 60.00 A Selection with buttons  and  .
 	<div style="border: 1px solid black; padding: 5px; text-align: center;"> <math>5</math>  <b>no</b>  <hr/> <i>F0</i> </div>	Fixed Zero 0, e.g. 3690 + 0 <i>no</i> ; <i>YES</i> Selection with buttons  and  .
 	<div style="border: 1px solid black; padding: 5px; text-align: center;"> <math>6</math>  <b>0.</b>  <hr/> <i>dP</i> </div>	Decimal point position <i>F0 = no</i> 0. 0 .00 .000 <i>F0 = YES</i> 0. .00 .000 .0000 Selection with buttons  and  .
 	<div style="border: 1px solid black; padding: 5px; text-align: center;"> <math>7</math>  <b>0</b>  <hr/> <i>S<sub>t</sub></i> </div>	Start value for indicating range and analog output. Setting possible from -9999 ... 9999 digit with buttons  and  . In case of modification new configuration of the alarm outputs is necessary.
 	<div style="border: 1px solid black; padding: 5px; text-align: center;"> <math>8</math>  <b>1000</b>  <hr/> <i>E<sub>n</sub></i> </div>	End value for indicating range and analog output. Setting possible from -9999 ... 9999 digit with buttons  and  . In case of modification new configuration of the alarm outputs is necessary. If $S_t > E_n$ , output works with a decreasing characteristic.
		

continue  
page 7

Button	Display	Description (Display graphic shows factory settings)
↓ ↺	8 	Switching performance output A1. Function <i>oFF</i> ; <i>o n L</i> (min); or <i>o n J</i> (max). If activated the start value will be loaded for set point. Selection with buttons ▲ and ▼.
↓ ↺	9 	Set point output A1. Setting possible from <i>S t</i> (start value) ... <i>E n</i> (end value) with buttons ▲ and ▼.
↓ ↺	10 	Hysteresis A1 Setting possible from <i>1</i> ... <i>9999</i> digit with buttons ▲ and ▼.
↓ ↺	11 	Switch-on delay time output A1. Setting possible from <i>0.00.00</i> ... <i>9.00.00</i> (h.mm.ss) with buttons ▲ and ▼.
↓ ↺	12 	Switch-off delay time output A1. Setting possible from <i>0.00.00</i> ... <i>9.00.00</i> (h.mm.ss) with buttons ▲ and ▼.
Note: Switching performance and set points for alarm outputs A1 ... A4 have to be configured in the same way.		
↓ ↺	13 	Analog output. <i>0 - 20</i> mA (0 - 10 V DC) or <i>4 - 20</i> mA (2 - 10 V DC). Changing from current to voltage output is load-dependent ( $\leq 500 \Omega$ = current output, $> 500 \Omega$ = voltage output). Selection with buttons ▲ and ▼.
↓ ↺	14 	Code for factory settings.
↓ ↺	15 	Programming lock. <i>oFF</i> = no lock <i>L o n F.</i> = configuration level locked <i>R L L</i> = all parameters locked Selection with buttons ▲ and ▼.
		Return to the working level

## Ordering code

A9648 -  1. -  2. -  3. -  4. -  5. -  6. -  7.

### 1. Terminal strip A

1	0 ... 0.900 mA	up to	0 ... 9.999 mA*	DC/AC <sub>TRMS</sub>
	0 ... 9.000 mA	up to	0 ... 99.99 mA*	DC/AC <sub>TRMS</sub>
	0 ... 90.0 mA	up to	0 ... 999.9 mA*	DC/AC <sub>TRMS</sub>
	0 ... 0.900 A	up to	0 ... 6.000 A*	DC/AC <sub>TRMS</sub>
	*(includes e.g. ±20 mA)			
	0 ... 4.50 A	up to	0 ... 60.00 A	AC <sub>TRMS</sub>

### 2. Terminal strip B

00	not installed		
2R	2 alarm outputs	relay	
2T	2 alarm outputs	transistor	

### 3. Terminal strip C

00	not installed		
2R	2 alarm outputs	relay	
2T	2 alarm outputs	transistor	
AO	analog output 0/4 ... 20 mA or 0/2 ... 10 V DC		

### 4. Terminal strip D Supply voltage

0	230 V AC	± 10 %	50-60 Hz
1	115 V AC	± 10 %	50-60 Hz
4	24 V AC	± 10 %	50-60 Hz
5	24 V DC	± 15 %	

### 5. Options

00	without option
01	min- and max-peak hold
07	display brightness

### 6. Unit (appears in the unit field)

### 7. Additional text (will be placed in the field for additional text max. 3 x 90 mm, HxW)

Custom configuration on request